T-1³/₄ (5 mm) Precision Optical Performance AlInGaP LED Lamps

Technical Data



HP SunPower Series
HLMP-ELxx
HLMP-EJxx
HLMP-EHxx
HLMP-EGxx

Features

- **Well Defined Spatial Radiation Patterns**
- **Viewing Angles:** 6°, 15°, 23°, 30°
- **High Luminous Output**
- **Colors:**
 - 590 nm Amber
 - 605 nm Orange
 - 615 nm Reddish-Orange
 - 626 nm Red
- **High Operating Temperature:**
 $T_{j,LED} = +130^{\circ}\text{C}$
- **Superior Resistance to Moisture**
- **Package Options:**
With or Without Lead Stand-Offs

Benefits

- **Viewing Angles Match Traffic Management Sign Requirements**
- **Colors Meet Automotive and Pedestrian Signal Specifications**
- **Superior Performance in Outdoor Environments**
- **Suitable for Autoinsertion onto PC Boards**

Applications

- **Traffic Management:**
 - Traffic Signals
 - Pedestrian Signals
 - Work Zone Warning Lights
 - Variable Message Signs
- **Commercial Outdoor Advertising:**
 - Signs
 - Marquees
- **Automotive:**
 - Exterior and Interior Lights

Description

These Precision Optical Performance AlInGaP LEDs provide superior light output for excellent readability in sunlight and are extremely reliable. AlInGaP LED technology provides extremely stable light output over long periods of time. Precision Optical Performance lamps utilize the aluminum indium gallium phosphide (AlInGaP) technology.

These LED lamps are untinted, nondiffused, T-1³/₄ packages incorporating second generation optics producing well defined spatial radiation patterns at specific viewing cone angles.

These lamps are made with an advanced optical grade epoxy, offering superior high temperature and high moisture resistance

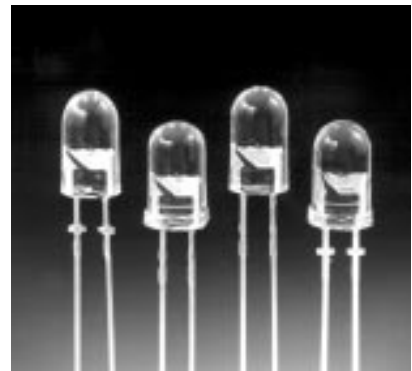

performance in outdoor signal and sign applications. The high maximum LED junction temperature limit of +130°C enables high temperature operation in bright sunlight conditions. The package epoxy contains both uv-a and uv-b inhibitors to reduce the effects of long term exposure to direct sunlight.

These lamps are available in two package options to give the designer flexibility with device mounting.

The HLMP-Exxx Series replace the HLMP-Dxxx and HLMP-Uxxx series products. A cross reference is found on page 10 of this data sheet.

Part Numbering Scheme

HLMP-E(1)(2)(3)-

(4)(5)(6)(7)(8)

where (1) = Color

“L” = 592 nm Amber

“J” = 605 nm Orange

“H” = 615 nm Reddish-orange

“G” = 626 nm Red

where (2)(3) = Viewing

Angle and Lead Standoffs

“08” = 6 degree without lead standoffs

“10” = 6 degree with lead standoffs

“15” = 15 degree without lead standoffs

“17” = 15 degree with lead standoffs

“24” = 23 degree without lead standoffs

“26” = 23 degree with lead standoffs

“30” = 30 degree without lead standoffs

“32” = 30 degree with lead standoffs

where (4) = Minimum Intensity Bin (refer to table on page 9)

where (5) = Maximum Intensity Bin (refer to table on page 9)

where (6) = Color Bin Selection

“0” = no color bin limitation

“K” = amber color bins 2 and 4 only (refer to table on page 9)

“4” = amber color bin 4 only (refer to table on page 9)

where (7)(8) = Mechanical or Packaging Option

“00” = bulk packaging, minimum increment 500/bag

“DD” = ammo pack, minimum increment 2000/box. Available for products shown in **BOLD** in selection guide.

Refer to the device selection guides for available combinations.

Device Selection Guide

Typical Viewing Angle $2\theta_{1/2}$ (Deg.) ^[4]	Color and Dominant Wavelength (nm), Typ. ^[3]	Lamps Without Standoffs on Leads (Outline Drawing A)	Lamps With Standoffs on Leads (Outline Drawing B)	Luminous Intensity I_v (mcd) ^[1,2] @ 20 mA	
				Min.	Max.
6° ^[5]	Amber 590	HLMP-EL08-SV000	HLMP-EL10-SV000	1650	6300
		HLMP-EL08-TW000	HLMP-EL10-TW000	2170	8300
		HLMP-EL08-UW000		2750	8300
		HLMP-EL08-UWK00*		2750	8300
		HLMP-EL08-UX000	HLMP-EL10-UX000	2750	10700
		HLMP-EL08-UXK00*		2750	10700
		HLMP-EL08-VW000		3600	8300
		HLMP-EL08-VWK00*		3600	8300
		HLMP-EL08-VX000		3600	10700
		HLMP-EL08-VX400**		3600	10700
		HLMP-EL08-VXK00*		3600	10700
		HLMP-EL08-VY000	HLMP-EL10-VY000	3600	13800
		HLMP-EL08-VYK00*		3600	13800

Notes:

1. The luminous intensity is measured on the mechanical axis of the lamp package.
2. The optical axis is closely aligned with the package mechanical axis.
3. The dominant wavelength, λ_d , is derived from the CIE Chromaticity Diagram and represents the color of the lamp.
4. $\theta_{1/2}$ is the off-axis angle where the luminous intensity is one half the on-axis intensity.
5. The intensity of narrow viewing angle lamps is measured at the intensity peak.

Part numbers in **bold** are recommended for new designs.

*HLMP-xLxx-xxK00 are selected to amber color bins 2 and 4 only.

**HLMP-xLxx-xx400 are selected to amber color bin 4 only.

Device Selection Guide (Continued)

Typical Viewing Angle $2\theta_{1/2}$ (Deg.) ^[4]	Color and Dominant Wavelength (nm), Typ. ^[3]	Lamps Without Standoffs on Leads (Outline Drawing A)	Lamps With Standoffs on Leads (Outline Drawing B)	Luminous Intensity I_v (mcd) ^[1,2] @ 20 mA		
				Min.	Max.	
6° ^[5]	Orange 605	HLMP-EJ08-TW000	HLMP-EJ10-TW000	2170	8300	
		HLMP-EJ08-UX000	HLMP-EJ10-UX000	2750	10700	
		HLMP-EJ08-VY000	HLMP-EJ10-VY000	3600	13800	
		HLMP-EJ08-WZ000	HLMP-EJ10-WZ000	4700	18400	
	Red-Orange 615	HLMP-EH08-SV000	HLMP-EH10-SV000	1650	6300	
		HLMP-EH08-TW000	HLMP-EH10-TW000	2170	8300	
		HLMP-EH08-UX000	HLMP-EH10-UX000	2750	10700	
		HLMP-EH08-VY000	HLMP-EH10-VY000	3600	13800	
	Red 626	HLMP-EG08-SV000	HLMP-EG10-SV000	1650	6300	
		HLMP-EG08-TW000	HLMP-EG10-TW000	2170	8300	
		HLMP-EG08-UW000		2750	8300	
		HLMP-EG08-UX000	HLMP-EG10-UX000	2750	10700	
		HLMP-EG08-VW000		3600	8300	
		HLMP-EG08-VX000		3600	10700	
		HLMP-EG08-VY000	HLMP-EG10-VY000	3600	13800	
	15°	Amber 590	HLMP-EL15-PS000	HLMP-EL17-PS000	765	2900
			HLMP-EL15-QR000		1000	2200
			HLMP-EL15-QRK00*		1000	2200
HLMP-EL15-QS000				1000	2900	
HLMP-EL15-QS400**				1000	2900	
HLMP-EL15-QSK00*				1000	2900	
HLMP-EL15-QT000			HLMP-EL17-QT000	1000	3700	
HLMP-EL15-QTK00*				1000	3700	
HLMP-EL15-RU000			HLMP-EL17-RU000	1300	4800	
HLMP-EL15-SV000			HLMP-EL17-SV000	1650	6300	
Orange 605		HLMP-EJ15-PS000	HLMP-EJ17-PS000	765	2900	
		HLMP-EJ15-QT000	HLMP-EJ17-QT000	1000	3700	
		HLMP-EJ15-RU000	HLMP-EJ17-RU000	1300	4800	
		HLMP-EJ15-SV000	HLMP-EJ17-SV000	1650	6300	

Notes:

1. The luminous intensity is measured on the mechanical axis of the lamp package.
2. The optical axis is closely aligned with the package mechanical axis.
3. The dominant wavelength, λ_d , is derived from the CIE Chromaticity Diagram and represents the color of the lamp.
4. $\theta_{1/2}$ is the off-axis angle where the luminous intensity is one half the on-axis intensity.
5. The intensity of narrow viewing angle lamps is measured at the intensity peak.

Part numbers in **bold** are recommended for new designs.

*HLMP-xLxx-xxK00 are selected to amber color bins 2 and 4 only.

**HLMP-xLxx-xx400 are selected to amber color bin 4 only.

Device Selection Guide (Continued)

Typical Viewing Angle 2θ 1/2 (Deg.) ^[4]	Color and Dominant Wavelength (nm), Typ. ^[3]	Lamps Without Standoffs on Leads (Outline Drawing A)	Lamps With Standoffs on Leads (Outline Drawing B)	Luminous Intensity I _v (mcd) ^[1,2] @ 20 mA	
				Min.	Max.
15°	Red-Orange 615	HLMP-EH15-PS000	HLMP-EH17-PS000	765	2900
		HLMP-EH15-QT000	HLMP-EH17-QT000	1000	3700
		HLMP-EH15-RU000	HLMP-EH17-RU000	1300	4800
		HLMP-EH15-SV000	HLMP-EH17-SV000	1650	6300
	Red 626	HLMP-EG15-PS000	HLMP-EG17-PS000	765	2900
		HLMP-EG15-QT000	HLMP-EG17-QT000	1000	3700
		HLMP-EG15-RU000	HLMP-EG17-RU000	1300	4800
		HLMP-EG15-SV000	HLMP-EG17-SV000	1650	6300
23°	Amber 590	HLMP-EL24-LP000	HLMP-EL26-LP000	345	1330
		HLMP-EL24-MQ000	HLMP-EL26-MQ000	450	1730
		HLMP-EL24-NQ000		590	1730
		HLMP-EL24-NQK00*		590	1730
		HLMP-EL24-NR000	HLMP-EL26-NR000	590	2200
		HLMP-EL24-NRK00*		590	2200
		HLMP-EL24-PQ000		765	1730
		HLMP-EL24-PQK00*		765	1730
		HLMP-EL24-PR000		765	2200
		HLMP-EL24-PR400**		765	2200
		HLMP-EL24-PRK00*		765	2200
		HLMP-EL24-PS000	HLMP-EL26-PS000	765	2900
		HLMP-EL24-PSK00*		765	2900
		Orange 605	HLMP-EJ24-MQ000	HLMP-EJ26-MQ000	450
	HLMP-EJ24-NR000		HLMP-EJ26-NR000	590	2200
	HLMP-EJ24-PS000		HLMP-EJ26-PS000	765	2900
	HLMP-EJ24-QT000		HLMP-EJ26-QT000	1000	3700
	Red-Orange 615	HLMP-EH24-LP000	HLMP-EH26-LP000	345	1330
		HLMP-EH24-MQ000	HLMP-EH26-MQ000	450	1730
		HLMP-EH24-NR000	HLMP-EH26-NR000	590	2200
		HLMP-EH24-PS000	HLMP-EH26-PS000	765	2900
	Red 626	HLMP-EG24-LP000	HLMP-EG26-LP000	345	1330
		HLMP-EG24-MQ000	HLMP-EG26-MQ000	450	1730
		HLMP-EG24-NR000	HLMP-EG26-NR000	590	2200
		HLMP-EG24-PS000	HLMP-EG26-PS000	765	2900

Device Selection Guide (Continued)

Typical Viewing Angle $2\theta_{1/2}$ (Deg.) ^[4]	Color and Dominant Wavelength (nm), Typ. ^[3]	Lamps Without Standoffs on Leads (Outline Drawing A)	Lamps With Standoffs on Leads (Outline Drawing B)	Luminous Intensity I_v (mcd) ^[1,2] @ 20 mA	
				Min.	Max.
30°	Amber 590	HLMP-EL30-LP000	HLMP-EL32-LP000	345	1330
		HLMP-EL30-MQ000	HLMP-EL32-MQ000	450	1730
		HLMP-EL30-NQ000		590	1730
		HLMP-EL30-NQK00*		590	1730
		HLMP-EL30-NR000	HLMP-EL32-NR000	590	2200
		HLMP-EL30-NRK00*		590	2200
		HLMP-EL30-PQ000		765	1730
		HLMP-EL30-PQK00*		765	1730
		HLMP-EL30-PR000		765	2200
		HLMP-EL30-PR400**		765	2200
		HLMP-EL30-PRK00*		765	2200
		HLMP-EL30-PS000	HLMP-EL32-PS000	765	2900
		HLMP-EL30-PSK00*		765	2900
		Orange 605	HLMP-EJ30-MQ000	HLMP-EJ32-MQ000	450
	HLMP-EJ30-NR000		HLMP-EJ32-NR000	590	2200
	HLMP-EJ30-PS000		HLMP-EJ32-PS000	765	2900
	HLMP-EJ30-QT000		HLMP-EJ32-QT000	1000	3700
	Red-Orange 615	HLMP-EH30-KN000	HLMP-EH32-KN000	270	1000
		HLMP-EH30-LP000	HLMP-EH32-LP000	345	1330
		HLMP-EH30-MQ000	HLMP-EH32-MQ000	450	1730
		HLMP-EH30-NR000	HLMP-EH32-NR000	590	2200
	Red 626	HLMP-EG30-KN000	HLMP-EG32-KN000	270	1000
		HLMP-EG30-LN000		345	1000
		HLMP-EG30-LP000	HLMP-EG32-LP000	345	1330
		HLMP-EG30-MN000		450	1000
		HLMP-EG30-MP000		450	1330
		HLMP-EG30-MQ000	HLMP-EG32-MQ000	450	1730
		HLMP-EG30-NR000	HLMP-EG32-NR000	590	2200

Notes:

1. The luminous intensity is measured on the mechanical axis of the lamp package.
2. The optical axis is closely aligned with the package mechanical axis.
3. The dominant wavelength, λ_d , is derived from the CIE Chromaticity Diagram and represents the color of the lamp.
4. $\theta_{1/2}$ is the off-axis angle where the luminous intensity is one half the on-axis intensity.
5. The intensity of narrow viewing angle lamps is measured at the intensity peak.

Part numbers in **bold** are recommended for new designs.

*HLMP-xLxx-xxK00 are selected to amber color bins 2 and 4 only.

**HLMP-xLxx-xx400 are selected to amber color bin 4 only.

Package Dimensions

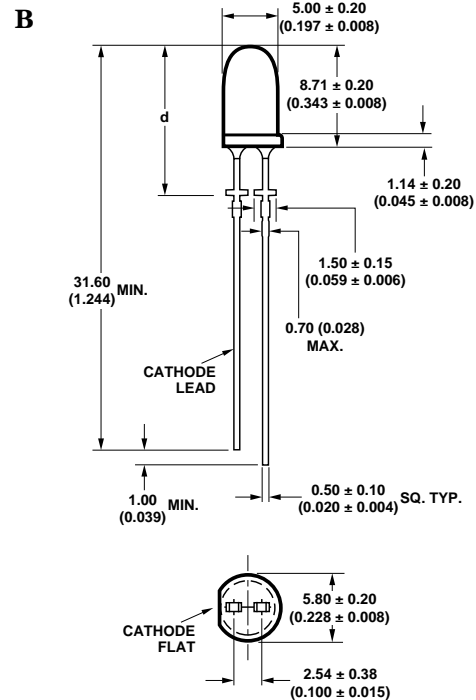
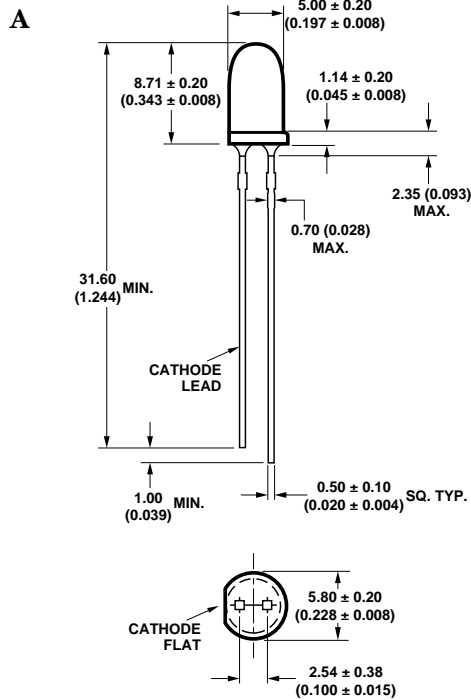

NOTES:

- ALL DIMENSIONS ARE IN MILLIMETERS (INCHES).
- LEADS ARE MILD STEEL, SOLDER DIPPED.
- TAPERS SHOWN AT TOP OF LEADS (BOTTOM OF LAMP PACKAGE) INDICATE AN EPOXY MENISCUS THAT MAY EXTEND ABOUT 1 mm (0.040 in.) DOWN THE LEADS.
- RECOMMENDED PC BOARD HOLE DIAMETERS:
 - LAMP PACKAGE A WITHOUT STAND-OFFS: FLUSH MOUNTING AT BASE OF LAMP PACKAGE = $1.143/1.067$ ($0.044/0.042$).
 - LAMP PACKAGE B WITH STAND-OFFS: MOUNTING AT LEAD STAND-OFFS = $0.965/0.889$ ($0.038/0.035$).
- FOR DOME HEIGHTS ABOVE LEAD STAND-OFF SEATING PLANE, d , LAMP PACKAGE B, SEE TABLE.

PART NO.	d
HLMP-XX10	12.37 ± 0.25 (0.487 ± 0.010)
HLMP-XX17	12.42 ± 0.25 (0.489 ± 0.010)
HLMP-XX26	12.52 ± 0.25 (0.493 ± 0.010)
HLMP-XX32	11.96 ± 0.25 (0.471 ± 0.010)

Absolute Maximum Ratings at $T_A = 25^\circ\text{C}$

DC Forward Current ^[1,2,3]	50 mA
Peak Pulsed Forward Current ^[2,3]	70 mA
Average Forward Current ^[3]	30 mA
Reverse Voltage ($I_R = 100 \mu\text{A}$)	5 V
LED Junction Temperature	130°C
Operating Temperature	-40°C to +100°C
Storage Temperature	-40°C to +120°C
Dip/Drag Soldering Temperature	260°C for 6 seconds
Through-the-Wave Preheat Temperature	145°C
Through-the-Wave Solder Temperature	245°C for 3 seconds
[1.59 mm (0.060 in.) below seating plane]	

Notes:

1. Derate linearly as shown in Figure 4.
2. For long term performance with minimal light output degradation, drive currents between 10 mA and 30 mA are recommended.
3. Please contact your Hewlett-Packard sales representative about operating currents below 10 mA.

Electrical/Optical Characteristics at $T_A = 25^\circ\text{C}$

Parameter	Symbol	Min.	Typ.	Max.	Units	Test Conditions
Forward Voltage Amber ($\lambda_d = 590 \text{ nm}$) Orange ($\lambda_d = 605 \text{ nm}$) Red-Orange ($\lambda_d = 615 \text{ nm}$) Red ($\lambda_d = 626 \text{ nm}$)	V_F		2.02 1.98 1.94 1.90	2.4	V	$I_F = 20 \text{ mA}$
Reverse Voltage	V_R	5	20		V	$I_F = 100 \mu\text{A}$
Peak Wavelength: Amber ($\lambda_d = 590 \text{ nm}$) Orange ($\lambda_d = 605 \text{ nm}$) Red-Orange ($\lambda_d = 615 \text{ nm}$) Red ($\lambda_d = 626 \text{ nm}$)	λ_{PEAK}		592 609 621 635		nm	Peak of Wavelength of Spectral Distribution at $I_F = 20 \text{ mA}$
Spectral Halfwidth	$\Delta\lambda_{1/2}$		17		nm	Wavelength Width at Spectral Distribution $1/2$ Power Point at $I_F = 20 \text{ mA}$
Speed of Response	τ_s		20		ns	Exponential Time Constant, e^{-t/τ_s}
Capacitance	C		40		pF	$V_F = 0, f = 1 \text{ MHz}$
Thermal Resistance	$R\theta_{\text{J-PIN}}$		240		$^\circ\text{C/W}$	LED Junction-to-Cathode Lead
Luminous Efficacy ^[1] Amber ($\lambda_d = 590 \text{ nm}$) Orange ($\lambda_d = 605 \text{ nm}$) Red-Orange ($\lambda_d = 615 \text{ nm}$) Red ($\lambda_d = 626 \text{ nm}$)	η_v		480 370 260 150		lm/W	Emitted Luminous Power/Emitted Radiant Power

Note:

1. The radiant intensity, I_e , in watts per steradian, may be found from the equation $I_e = I_v/\eta_v$, where I_v is the luminous intensity in candelas and η_v is the luminous efficacy in lumens/watt.

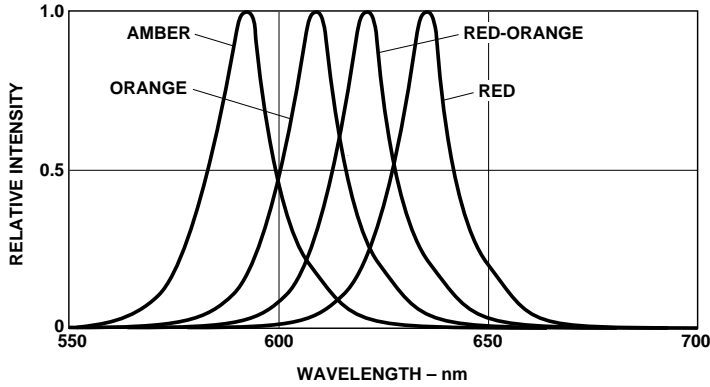

Figure 1. Relative Intensity vs. Peak Wavelength.

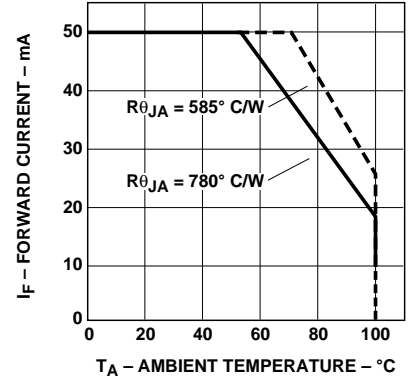

Figure 4. Maximum Forward Current vs. Ambient Temperature. Derating Based on $T_{JMAX} = 130^{\circ}C$.

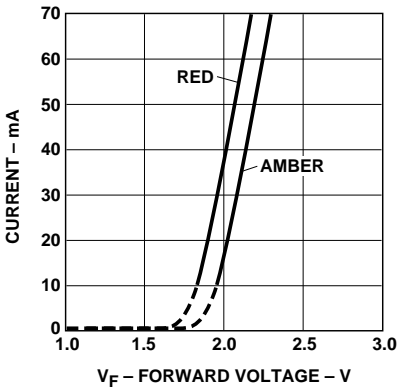

Figure 2. Forward Current vs. Forward Voltage.

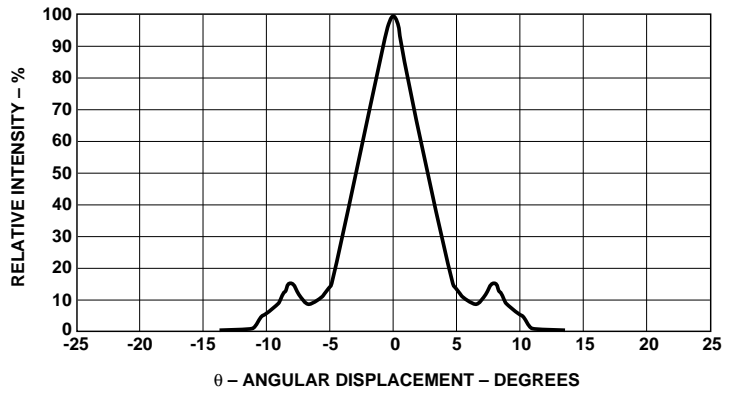

Figure 5. Representative Spatial Radiation Pattern for 6° Viewing Angle Lamps.

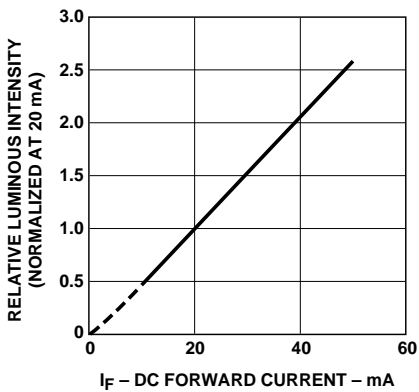

Figure 3. Relative Luminous Intensity vs. Forward Current.

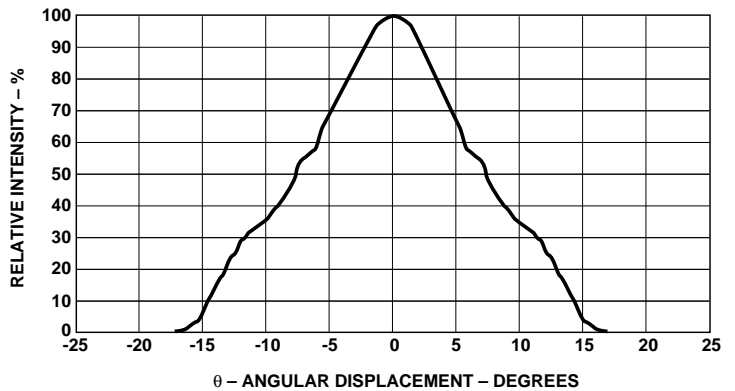

Figure 6. Representative Spatial Radiation Pattern for 15° Viewing Angle Lamps.

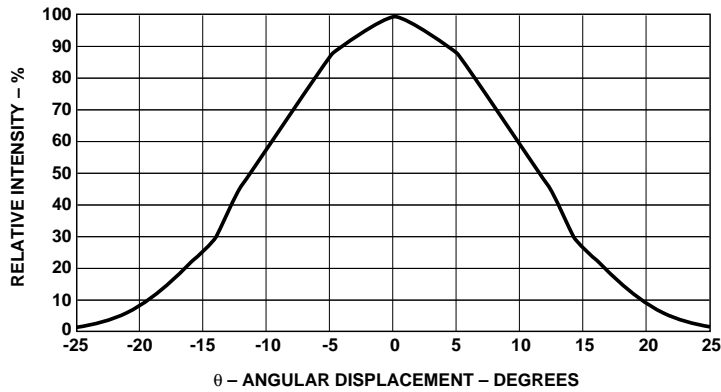

Figure 7. Representative Spatial Radiation Pattern for 23° Viewing Angle Lamps.

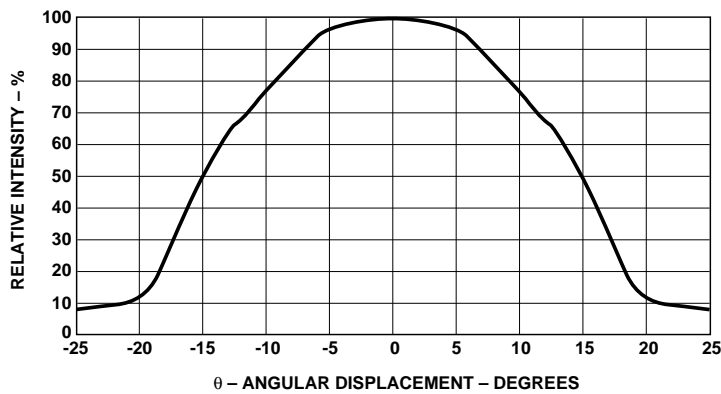

Figure 8. Representative Spatial Radiation Pattern for 30° Viewing Angle Lamps.

Intensity Bin Limits (mcd at 20 mA)

Bin Name	Min.	Max.
K	310	400
L	400	520
M	520	680
N	680	880
P	880	1150
Q	1150	1500
R	1500	1900
S	1900	2500
T	2500	3200
U	3200	4200
V	4200	5500
W	5500	7200
X	7200	9300
Y	9300	12000
Z	12000	16000

Tolerance for each bin limit is $\pm 15\%$.

HLMP-xLxx Color Bin Limits (nm at 20 mA)

Bin Name	Min.	Max.
1	584.5	587.0
2	587.0	589.5
4	589.5	592.0
6	592.0	594.5

Tolerance for each bin limit is ± 0.5 nm.

Note:

- Bin categories are established for classification of products. Products may not be available in all bin categories.

Part Number Cross Reference

Hewlett-Packard Precision Optical Performance T-1³/₄ AlInGaP II lamps part numbers are changing. The advantages of the new part numbering system include:

- specification of maximum intensities
- for comparison/substitution purposes, easier recognition of parts which are the same color and viewing angle, but differ only in intensity and/or color bin selection

In each case, except for HLMP-DL24 and DL26, the new part number is an exact replacement for the old part number.

Old Part Number	New Part Number
HLMP-DG08	HLMP-EG08-UX000
HLMP-DG10	HLMP-EG10-UX000
HLMP-DG15	HLMP-EG15-RU000
HLMP-DG17	HLMP-EG17-RU000
HLMP-DG24	HLMP-EG24-PS000
HLMP-DG26	HLMP-EG26-PS000
HLMP-DG30	HLMP-EG30-MQ000
HLMP-DG32	HLMP-EG32-MQ000
HLMP-DH08	HLMP-EH08-UX000
HLMP-DH10	HLMP-EH10-UX000
HLMP-DH15	HLMP-EH15-RU000
HLMP-DH17	HLMP-EH17-RU000
HLMP-DH24	HLMP-EH24-PS000
HLMP-DH26	HLMP-EH26-PS000
HLMP-DH30	HLMP-EH30-MQ000
HLMP-DH32	HLMP-EH32-MQ000
HLMP-DJ08	HLMP-EJ08-WZ000
HLMP-DJ10	HLMP-EJ10-WZ000
HLMP-DJ15	HLMP-EJ15-RU000
HLMP-DJ17	HLMP-EJ17-RU000
HLMP-DJ24	HLMP-EJ24-QT000
HLMP-DJ26	HLMP-EJ26-QT000
HLMP-DJ30	HLMP-EJ30-PS000
HLMP-DJ32	HLMP-EJ32-PS000
HLMP-DL08	HLMP-EL08-VY000
HLMP-DL10	HLMP-EL10-VY000
HLMP-DL15	HLMP-EL15-SV000
HLMP-DL17	HLMP-EL17-SV000
HLMP-DL24	HLMP-EL25-QT000 or HLMP-EL24-PS000*
HLMP-DL26	HLMP-EL27-QT000 or HLMP-EL26-PS000*
HLMP-DL30	HLMP-EL30-PS000
HLMP-DL32	HLMP-EL32-PS000

*The new parts are not exact replacements for HLMP-DL2x. HLMP-EL2x-QT000 are AlInGaP II lamps of equivalent intensity. HLMP-EL2x-PS000 are AlInGaP lamps of slightly lower intensity.

Old Part Number	New Part Number
HLMP-UG06	HLMP-EG08-SV000
HLMP-UG07	HLMP-EG10-SV000
HLMP-UG13	HLMP-EG15-PS000
HLMP-UG14	HLMP-EG17-PS000
HLMP-UG22	HLMP-EG24-LP000
HLMP-UG23	HLMP-EG26-LP000
HLMP-UG28	HLMP-EG30-KN000
HLMP-UG29	HLMP-EG32-KN000
HLMP-UH06	HLMP-EH08-SV000
HLMP-UH07	HLMP-EH10-SV000
HLMP-UH13	HLMP-EH15-PS000
HLMP-UH14	HLMP-EH17-PS000
HLMP-UH22	HLMP-EH24-LP000
HLMP-UH23	HLMP-EH26-LP000
HLMP-UH28	HLMP-EH30-KN000
HLMP-UH29	HLMP-EH32-KN000
HLMP-UJ06	HLMP-EJ08-TW000
HLMP-UJ07	HLMP-EJ10-TW000
HLMP-UJ13	HLMP-EJ15-PS000
HLMP-UJ14	HLMP-EJ17-PS000
HLMP-UJ22	HLMP-EJ24-MQ000
HLMP-UJ23	HLMP-EJ26-MQ000
HLMP-UJ28	HLMP-EJ30-MQ000
HLMP-UJ29	HLMP-EJ32-MQ000
HLMP-UL06	HLMP-EL08-SV000
HLMP-UL07	HLMP-EL10-SV000
HLMP-UL13	HLMP-EL15-PS000
HLMP-UL14	HLMP-EL17-PS000
HLMP-UL22	HLMP-EL24-MQ000
HLMP-UL23	HLMP-EL26-MQ000
HLMP-UL28	HLMP-EL30-LP000
HLMP-UL29	HLMP-EL32-LP000



www.hp.com/go/led_lamps

For technical assistance or the location of your nearest Hewlett-Packard sales office, distributor or representative call:

Americas/Canada: 1-800-235-0312 or 408-654-8675

Far East/Australasia: Call your local HP sales office.

Japan: (81 3) 3335-8152

Europe: Call your local HP sales office.

Data subject to change.

Copyright © 1998 Hewlett-Packard Co.

Obsoletes 5968-0948E

5968-2279E (10/98)